

RS232 and 1-Wire Communication Board

Introduction

The Com Pi from AB Electronics is a communication board supporting RS232 and 1-Wire[®] protocols. A 5V buffered I²C port is also provided on the board.

The RS232 port is connected to the UART port on the Raspberry Pi using a MAX3232 interface. The MAX3232 IC converts the 3.3V UART port to RS232 voltages allowing communication with RS232 compatible devices over a DB9 serial cable or with the use of a null-modem cable the board allows terminal access with linux on the Raspberry Pi using a terminal application. The RS232 port can be accessed through the DB9 port or the solder points on the PCB. For details on configuring the RS232 communication on the Raspberry Pi visit

<http://www.abelectronics.co.uk/raspberrypi-serialportusage/info.aspx>

The 1-Wire[®] port is based around a DS2482-100 I²C to 1-Wire[®] bridge device. The DS2482-100 provides bi-directional protocol conversion between the I²C port on the Raspberry Pi and any attached 1-Wire[®] slave devices. An ESD Protection Diode is used to protect the Com Pi and Raspberry Pi from electrostatic spikes on the 1-Wire[®] port. Connections to the 1-Wire[®] port can be made through the RJ-12 socket or the solder points on the PCB. For details on configuring and using the 1-Wire[®] port on your Raspberry Pi visit

<http://www.abelectronics.co.uk/owfs-and-compi/info.aspx>

Wiring diagrams for the RS232 and 1-Wire[®] ports can be found on page 2 of this datasheet.

A 5V input port is also provided allowing you to use an external power supply on the 1-Wire[®] interface, reducing the load on the Raspberry Pi. If you choose to use the external 5V input please remove the jumper on the board to isolate the Raspberry Pi 5V bus.

Board Layout

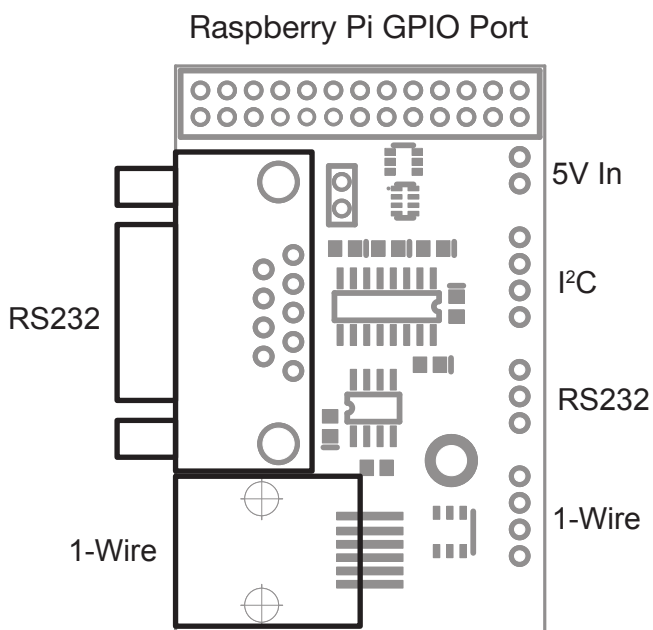

Features

- RS232 Master Port.
- Control the Raspberry Pi over RS232 or connect to external serial accessories.
- 1-Wire[®] to I²C host interface with ESD protection diode.
- Stackable with other Raspberry Pi accessory boards.
- Hardware mounting kit and GPIO extension included.
- Buffered 5V I²C port.
- External 5V power input for 1-Wire[®] interface.

Electrical Characteristics

Vdd (5V input pin) 5.0V
 Maximum current on 1-Wire pins ±20 mA

I²C SDA/SCL voltage 5.0 V
 I²C port current 100 mA

Installation

The Com Pi comes with a mounting post which reduces the strain on the Raspberry Pi GPIO port when cables are connected to the RS232 or 1-Wire[®] ports.

1. Place a washer on the bolt and push it up through the mounting hole on the underside of the Raspberry Pi.
2. Place a washer on the bolt on top of the Raspberry Pi and screw the mounting post down until it is hand tight. (Over tightening can cause serious damage to the Raspberry Pi)
3. Add a washer to the top of the mounting post and push the Com Pi down onto the GPIO port and mounting post.
4. Place the final washer down onto the mounting post and screw the nut down tight against the Com Pi.

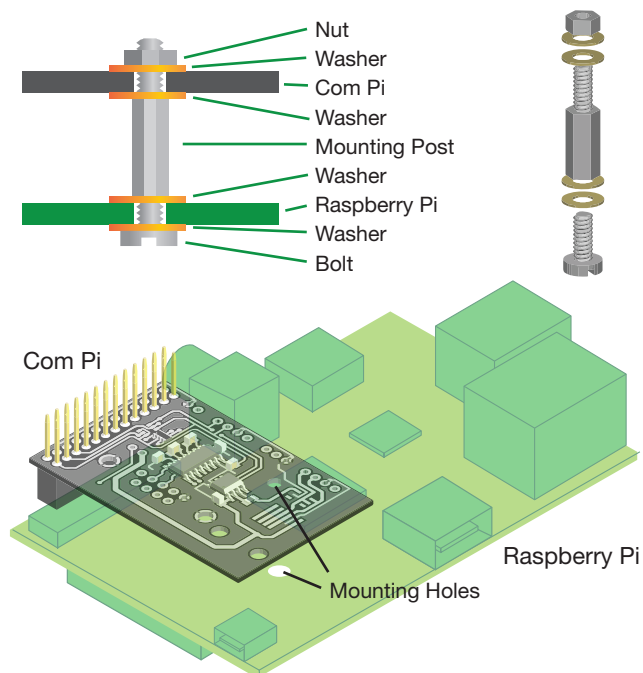

Connecting to the RS232 Port

The RS232 port on the Com Pi can be accessed through the male DB9 socket or the solder points on the PCB. The DB9 socket is configured as a master socket like you will find on desktop computers allowing you to connect external serial devices with a standard RS232 cable.

The pinout connections for the RS232 port are shown below:

Pin Usage

Pin	Usage
1	N/C
2	RX (data receive)
3	TX (data transmit)
4	N/C
5	Ground
6	N/C
7	N/C
8	N/C
9	N/C

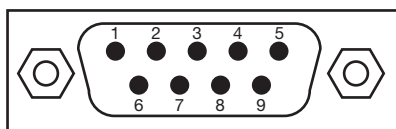

DB9 Female Socket as viewed from the front of the Com Pi

Using the RS232 port for terminal connections

The RS232 port can be used for remote terminal connections on the Raspberry Pi allowing remote access and control without the need for an ethernet connection. In order to connect the Com Pi to a desktop computer you will need to use a Null-Modem cable. A wiring diagram for making a Null-Modem cable can be found below. For details on configuring the RS232 communication on the Raspberry Pi visit <http://www.abelectronics.co.uk/raspberrypi-serialportusage/info.aspx>

Null-Modem Cable

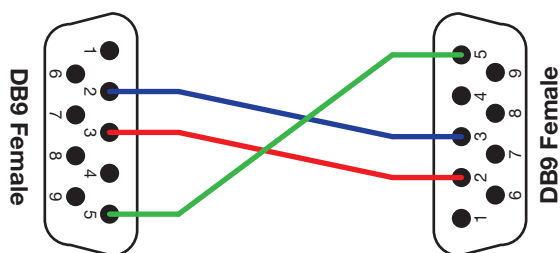

Connector 1	Connector 2	Function
2	3	Rx ← Tx
3	2	Tx → RX
5	5	Ground

Connecting to the 1-Wire® Port

The 1-Wire® port on the Com Pi can be accessed through the female RJ12 socket or the solder points on the PCB. An ESD protection diode is fitted between the RJ12 port and the 1-Wire interface IC.

The pinout connections for the RJ12 port are shown below:

Pin Usage

Pin	Usage
1	N/C
2	N/C
3	RT (1-Wire Return/Ground, ESD Protected)
4	OW (1-Wire Data, ESD Protected)
5	Ground
6	5V

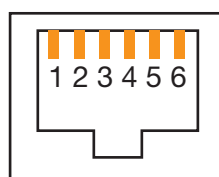

RJ12 Socket as viewed from the front of the Com Pi

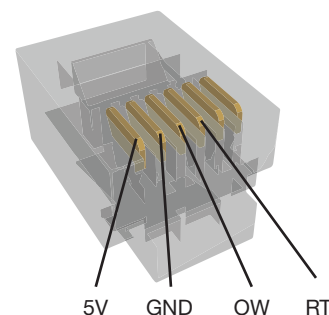

RefDes	Value	Type
C1	100nF	CAP
C2	100nF	CAP
C3	100nF	CAP
C4	100nF	CAP
C5	100nF	CAP
C7	100nF	CAP
J1		DB9M
J2		JUMPER
R5	100R	RES
R6	2K2	CAY16-222J4LF
U1		Raspberry Pi
U2		1-Wire RJ12
U3		RS232 Port
U4		DS2482S-100
U5		MAX3232EID
U6		DS9503
U7		FDC630IN
U10		i2c Port
U11		1-Wire Port
U12		5V Power

